



How to Choose Switching Controller for Design

Prepared by: Kahou Wong
ON Semiconductor

APPLICATION NOTE

This article is to present a way to choose a switching controller for design in the Switching Controllers Selector Guide SGD514/D from ON Semiconductor.
(<http://www.onsemi.com/pub/Collateral/SGD514-D.PDF>)

1. Define the Specification

The first step is to define what the specification is. The three key fundamental specification of a power circuit are: (1) input voltage range $V_{in(min)}$ and $V_{in(max)}$, (2) output voltage and current, and (3) isolation needed or not. Once it is defined, a suitable topology can be selected.

2. Select a Topology

Then, we have to know the features and differences between the switching topologies and make a smart choice among them. A bad choice will lead us in a bad direction to start. Table 1 shows a summary of switching topology. Common switching topologies can be classified into two groups: Isolated (flyback, forward, half-bridge and full-bridge) and non-isolated (buck, boost, buck-boost, cuk and sepic).

Table 1. Topology Summary

Topology	Nature	Conversion	Typical Power	Duty	MOSFET Stress
Buck	Step Down	$V_{out} = D \cdot V_{in}$	Up to 100 W	< 100%	V_{in}
Boost	Step Up	$V_{out} = \frac{1}{1-D} \cdot V_{in}$	Up to 100 W	< 100%	V_{out}
Buck-Boost	Inverting	$V_{out} = \frac{-D}{1-D} \cdot V_{in}$	Up to 100 W	< 100%	$V_{in} - V_{out}$
Cuk	Inverting and Lowest Ripple	$V_{out} = \frac{-D}{1-D} \cdot V_{in}$	Up to 100 W	< 100%	$> V_{in}$ and $> V_{out}$
Sepic	Step Up or Down	$V_{out} = \frac{D}{1-D} \cdot V_{in}$	Up to 100 W	< 100%	$V_{in} + V_{out}$
Flyback	Isolated, Step Up or Down	$V_{out} = \frac{n_2}{n_1} \cdot \frac{D}{1-D} \cdot V_{in}$	Up to 100 W	< 100%	$> V_{in}$
Forward		$V_{out} = \frac{n_2}{n_1} \cdot D \cdot V_{in}$	Up to 200 W	< 100%	$> V_{in}$
2-Switch Forward		$V_{out} = \frac{n_2}{n_1} \cdot D \cdot V_{in}$	Up to 500 W	< 50%	V_{in}
Half-Bridge		$V_{out} = \frac{n_2}{n_1} \cdot \frac{D}{2} \cdot V_{in}$	Up to 500 W	< 50%	V_{in}
Push-Pull		$V_{out} = \frac{n_2}{n_1} \cdot \frac{D}{2} \cdot V_{in}$	Up to 1.0 kW	< 50%	$2.0 V_{in}$
Full-Bridge		$V_{out} = \frac{n_2}{n_1} \cdot D \cdot V_{in}$	Up to 2.0 kW	< 50%	V_{in}

Isolated topologies get transformer that provides galvanic isolation but the non-isolated topologies do not. It means that isolated topology can work for non-isolation applications but non-isolated topology cannot work for isolation applications. The transformer turn ratio (n_2 / n_1) also allows more flexibility for duty ratio design. It makes isolated topologies sometimes better choices than non-isolated topologies even the isolation is not required in the applications.

The major difference between isolated topologies is the power level, and the major difference between the non-isolated topologies is the relationship between input voltage and output voltage conversion (i.e., step up or step down). Buck and boost are the most widely used non-isolated topologies that need the fewest circuit components, but they cannot suit application that needs both step up and step down. In this case, the buck-boost is a good choice if the polarity of the output voltage is not important, such as battery power/charging application. Otherwise, the sepic and cuk that need more circuit components are the remaining non-isolated choices.

The power level in Table 1 is only a guide on the typical power range of each topology. The actual power range of a topology is basically limited by the maximum allowable voltage, current, frequency and temperature rise in semiconductor, magnetic and capacitor areas. For instance, a 1.0 A wire can carry 1.0 W at 1.0 V and 100 W at 100 V.

3. Biasing the Controller

Switching controller needs a supply voltage to make it functional. It must be biased first to get some output voltage. Hence, the V_{CC} operating range of the controller is absolutely important in the selection. The maximum rating of the V_{CC} pin limits the maximum $V_{CC(max)}$. The V_{CC} Undervoltage Lock-Out (UVLO) upper threshold provides the minimum startup V_{CC} voltage, $V_{CC(startup)}$. The V_{CC} UVLO lower threshold provides the minimum operating V_{CC} voltage after startup.

In most of the cases, we don't want another power supply to bias the V_{CC} voltage of a switching controller. Therefore, the minimum input voltage must be larger than the minimum startup V_{CC} voltage of the switching controller, i.e.:

$$V_{in(min)} > V_{CC(startup)} \quad (eq. 1)$$

On the other side, if the maximum input voltage is smaller than $V_{CC(max)}$, it is the perfect case that the input voltage can directly connect and power the V_{CC} of the switching controller in Figure 1.

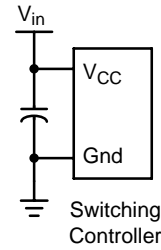

Figure 1. Perfect Case

Otherwise, if the maximum input voltage is too high for the V_{CC} pin to handle, an external resistor is needed to share the excessive voltage difference to prevent damage of the switching controller in Figure 2. The value of the resistor depends on the maximum allowable startup charging time of the V_{CC} capacitor and the maximum allowable power dissipation of the resistor.

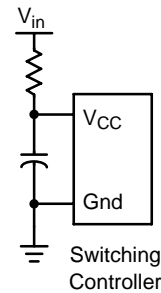

Figure 2. V_{CC} Biasing through Resistor

Since the added resistor always consumes power, even an auxiliary V_{CC} supply voltage is available after startup, a modification to turn off the resistor is shown in Figure 3. The transistor conducts only at startup and will be opened later. After startup, an auxiliary V_{CC} supply is available and provides the V_{CC} biasing voltage. As long as the biasing voltage is higher than the zener reference voltage and the $V_{BE(ON)}$ of the transistor, the transistor will be off. It is noted that the operating current of the zener diode needs to be small to save the power dissipated there because it is always operating when input voltage V_{in} is applied.

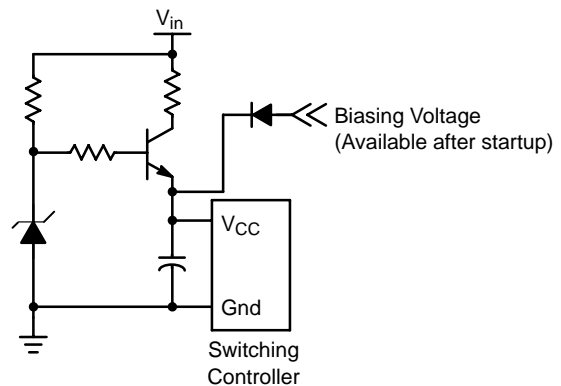

Figure 3. Disable the Resistor after Startup

Some of the controllers in ON Semiconductor offer High-Voltage (HV) startup features such as the NCP1200 series. It integrates the complex circuit in Figure 3 to Figure 4.

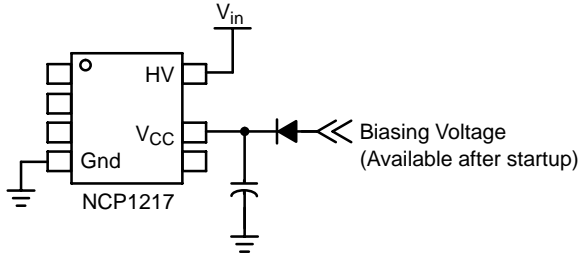

Figure 4. Integrated Startup

An auxiliary V_{CC} supply is still needed in this configuration. A further modification is so-called “Dynamic Self Supply (DSS)” in Figure 5 that needs no auxiliary V_{CC} supply because the HV pin will charge up the V_{CC} voltage when V_{CC} is below a threshold.

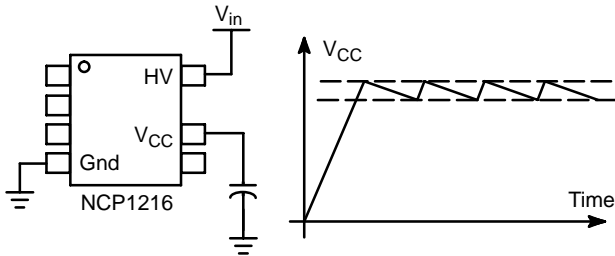

Figure 5. Dynamic Self Supply

Depending on the application topology, an additional auxiliary winding on the main power inductor or transformer can deliver a roughly regulated biasing voltage that is proportional to the regulated output voltage for the V_{CC} .

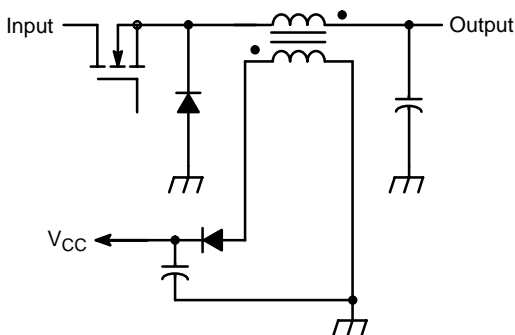

Figure 6. Auxiliary Winding in Buck

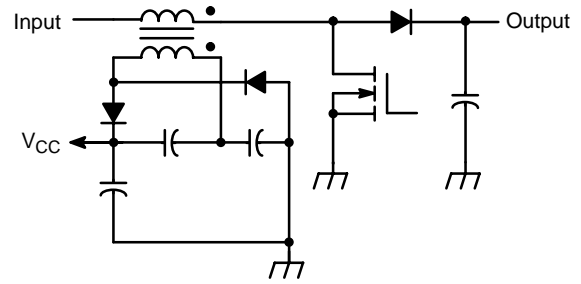

Figure 7. Auxiliary Winding in Boost

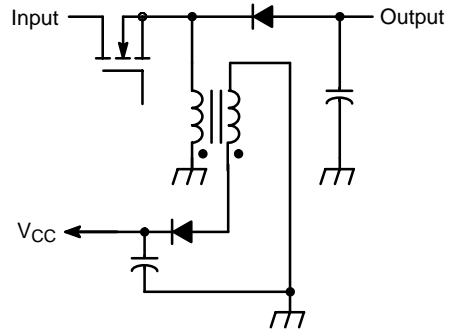

Figure 8. Auxiliary Winding in Buck-Boost

4. Duty Ratio Limitation

Duty ratio is the ratio of MOSFET on time to the switching period. It limits the input and output voltage ratio. A switching controller usually states its maximum duty ratio. This information tells you how the output voltage can go based on the input voltage. For example, regardless of conduction loss a buck converter needs 70% duty ratio to step down 10 V to 7.0 V. It cannot be done by a buck topology with a 50% maximum duty ratio controller.

The duty ratio indirectly increases with current. Because of a significant increase of conduction loss in higher current, some voltage disappears as resistive IR drop and output voltage drops. In this case, the controller needs to maintain the output voltage constant by increasing the duty ratio.

Large duty ratio is not desirable because of topology limitation and maximum power control. Two-transistor forward, pull-push, half-bridge and full-bridge require duty smaller than 50% for the transformer reset. 100% duty means the inductor or transformer continuously draws current from input and that is undesirable and something will be damaged in the circuit eventually.

5. Voltage Reference

The output voltage is usually set by a pair of external resistor and a voltage reference. Therefore, the voltage reference in the switching controller is also a concern. It is noted that the output voltage and reference voltage is on the secondary side in the isolated topologies, and hence most of the isolated-topology controller does not have an internal reference because the controller is located on the primary side. When the controller does not have a reference voltage,

an external zener diode or TL431 is needed to act as a reference for the regulation.

6. Be Creative

A switching controller is only one of the components in the power converter. With some creativity, the application areas of the controller can be extended. The following are some examples.

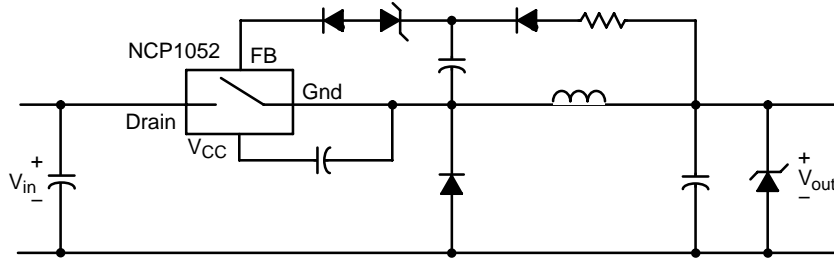

Figure 9. Flyback Controller in Buck Topology

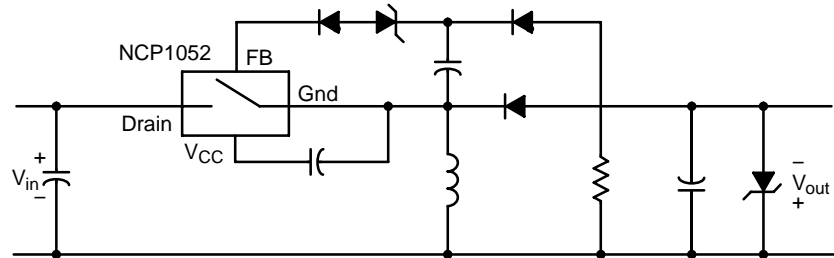

Figure 10. Flyback Controller in Buck-Boost Topology

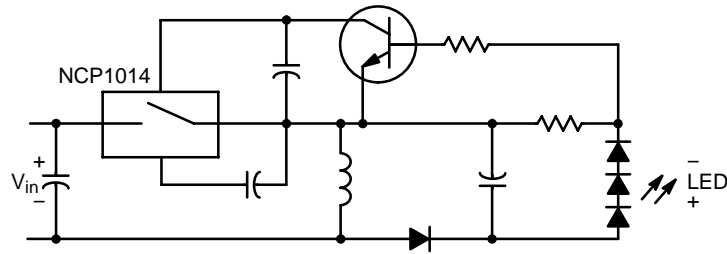

Figure 11. Flyback Controller in Buck-Boost Topology and Unimportant to the Output Ground

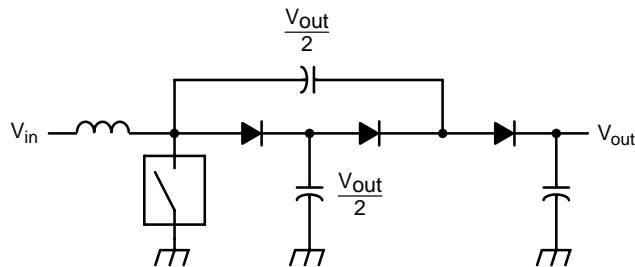

Figure 12. Boost Controller with Increasing Voltage Capability

Notes

ON Semiconductor and  are registered trademarks of Semiconductor Components Industries, LLC (SCILLC). SCILLC reserves the right to make changes without further notice to any products herein. SCILLC makes no warranty, representation or guarantee regarding the suitability of its products for any particular purpose, nor does SCILLC assume any liability arising out of the application or use of any product or circuit, and specifically disclaims any and all liability, including without limitation special, consequential or incidental damages. "Typical" parameters which may be provided in SCILLC data sheets and/or specifications can and do vary in different applications and actual performance may vary over time. All operating parameters, including "Typicals" must be validated for each customer application by customer's technical experts. SCILLC does not convey any license under its patent rights nor the rights of others. SCILLC products are not designed, intended, or authorized for use as components in systems intended for surgical implant into the body, or other applications intended to support or sustain life, or for any other application in which the failure of the SCILLC product could create a situation where personal injury or death may occur. Should Buyer purchase or use SCILLC products for any such unintended or unauthorized application, Buyer shall indemnify and hold SCILLC and its officers, employees, subsidiaries, affiliates, and distributors harmless against all claims, costs, damages, and expenses, and reasonable attorney fees arising out of, directly or indirectly, any claim of personal injury or death associated with such unintended or unauthorized use, even if such claim alleges that SCILLC was negligent regarding the design or manufacture of the part. SCILLC is an Equal Opportunity/Affirmative Action Employer. This literature is subject to all applicable copyright laws and is not for resale in any manner.

PUBLICATION ORDERING INFORMATION

LITERATURE FULFILLMENT:

Literature Distribution Center for ON Semiconductor
P.O. Box 61312, Phoenix, Arizona 85082-1312 USA
Phone: 480-829-7710 or 800-344-3860 Toll Free USA/Canada
Fax: 480-829-7709 or 800-344-3867 Toll Free USA/Canada
Email: orderlit@onsemi.com

N. American Technical Support: 800-282-9855 Toll Free
USA/Canada

Japan: ON Semiconductor, Japan Customer Focus Center
2-9-1 Kamimeguro, Meguro-ku, Tokyo, Japan 153-0051
Phone: 81-3-5773-3850

ON Semiconductor Website: <http://onsemi.com>

Order Literature: <http://www.onsemi.com/litorder>

For additional information, please contact your
local Sales Representative.